

# Hybrid Mobile Interactive Services combining DVB-T and GPRS

**Christian Rauch**

*Vodafone Pilotentwicklung GmbH (formerly Mannesmann Pilotentwicklung GmbH)  
Chiemgaustr. 116, 81549 München, Tel. +49 89 95410-0, email: rchristian@mpe-muc.de*

**Wolfgang Kellerer, Peter Sties**

*Munich University of Technology (TUM), Institute of Communication Networks  
Arcisstr. 21, 80333 München, Tel. +49 89 289- 23505/-23508, email: { kellerer | sties } @ ei.tum.de*

## Abstract

Scarce wireless bandwidth and limited capabilities of cellular systems demand new, complementary techniques for the provision of wireless multimedia services. Hybrid systems coupling for example the digital terrestrial television (DVB-T) system with cellular communication systems provide a feasible solution to this problem. This paper describes a hybrid system, composed of DVB-T and the new GSM packet-switching standard GPRS (General Packet Radio Service) to enable wireless multimedia services. The coupling is performed by an IP-backbone network. For the development of the server structure we rely on existing models for hybrid systems from literature. The DVB-T network, which is designed for the broadcast of television programs, is a key component of our concept to supply interactive broadcast services. We discuss an interactive, electronic multimedia-newspaper service and a near-media-on-demand service “MP3-music-delivery” as examples. Besides the system concept, our prototype implementation of the MP3-service is described. The progress in the development of compact multimedia handheld terminals makes it possible to address a rapidly growing market for mobile applications with such service ideas. However, the regulation of broadcasting and the strategies for the introduction of DVB-T has to be regarded, as it will exert big influence on the commercialization of such service offerings.

## 1 Introduction

The expected growth potential of mobile data services will lead to the introduction of enhanced and even new mobile communication systems, like GPRS and UMTS. However, even these systems will not be able to offer sufficient capacity to be suitable for the whole range of mobile applications and to cope with the increasing number of subscribers within the limited frequency spectrum. Especially broadcast oriented services that provide multimedia content could be offered more efficiently through a digital broadcast system like the digital terrestrial television (DVB-T), which provides a broadband extension of existing bandwidth for wireless services.

The coupling of DVB-T with packet switched cellular systems, e. g. with GPRS, would thus combine the advantages of broadband broadcast with the possibility of individual interaction in a so-called hybrid system (see Fig. 1).

### 1.1 Service Scenarios

To identify service ideas that especially benefit from a hybrid system like that, a classification and evaluation of attractive ideas for mobile applications

on the basis of the underlying system characteristics is necessary. So-called interactive broadcast services are in our focus, as they benefit from the capability of DVB-T to efficiently broadcast big amounts of data.

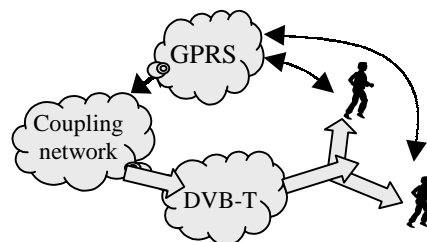

**Fig. 1** Hybrid system of DVB-T and GPRS

The combination with a narrow-band, individual interaction channel over a packet based media (e.g. GPRS, (compare Section 3.3) complements the technical system.

Concrete attractive examples are an electronic newspaper (“E-Newspaper”) and broadcast based near-media-on-demand services like “MP3-music-delivery”. The “E-Newspaper” would offer general news with multimedia extensions (images and video clips). In addition to that, local offers containing information for spare time activities in big cities are possible, provided for example by webcams. This

content is broadcasted over DVB-T, and is periodically updated. GPRS offers each user the possibility for personal interaction. Forms of interaction can contain an automatic feedback (statistics of local access to the different sites) or personal feedback (discussion board, letter to the editor).

With the MP3 service a user can individually request a music file. The requests are collected and the files are broadcasted in the concerned transmission area. An encoding mechanism, comparable with “Pay TV” allows only the users, who pay to access these files.

Besides these additional data services, a hybrid system would also enable mobile interactive television. In this case, the interaction channel would transmit additional information in a personalized and location-dependent way, synchronized to the actual broadcast content, for example user-profile dependent advertising or information about local events related to the TV program. Further special offerings could be chats or instant messaging groups to fans of favorite TV soap programs.

In the remainder of this paper we will describe a hybrid system combining DVB-T and GPRS. The system concept is based on results of the ACTS MEMO project [1] whereas for prototyping we refer to a platform developed at the Munich University of Technology [2]. Before we describe the hybrid concept and system structure in Section 3, we shortly explain the main characteristics of the two used wireless systems in the next section. In Section 4 we explain the system features and protocols for two distinguished service classes and give an overview on our prototype implementation. A discussion of realization aspects, containing terminals and regulatory questions concludes our work.

## 2 The Wireless Infrastructure

For an efficient provisioning of services like the ones described in the previous section, broadband broadcast networks have to be combined with cellularmobile communication networks.. Concerning the broadcast networks, the Digital Audio Broadcasting (DAB) and the terrestrial Digital Video Broadcasting (DVB-T), both seems to be well suited for the provisioning of additional services, as they already provide means to supply new multimedia services. For our hybrid system, we chose DVB-T as broadcast network, as it provides more bandwidth than DAB. As interaction network, we consider GPRS, being available in 2001. As GPRS is already packet-oriented, our considerations can be transferred to UMTS, which will be put into practice in 2003.

### 2.1 DVB-T

DVB-T is the standard for digital, terrestrial television in Europe and beyond [3]. The MPEG2-technology for data compression and multiplexing makes it possible to use the existing frequency channels for a multiplied number of TV programs or equivalents. Furthermore, IP data can be encapsulated directly into the MPEG2-transport stream using the Multi Protocol Encapsulation method (MPE), standardized within the DVB system [4]. Thus, additional data services can be transported over DVB-T, independently from the TV program offers (Fig. 2). The transmission parameters of DVB-T concerning modulation scheme and error coding rate can be configured in various combinations to meet the requirements of different reception situations. By this means a DVB-T network can be designed for mobile reception. Besides, the multi-carrier modulation scheme, called COFDM (*Coded Orthogonal Frequency Division Multiplex*) allows to build up single frequency networks, in which neighboring transmitters are using the same frequency. This supports a more economic use of the available spectrum. Depending on the number of frequency sub carriers, a 2k mode or a 8k mode is possible. The former allows a much higher maximum speed for mobile reception (about 400 km/h versus 100 km/h), whereas the latter permits bigger distances between transmitter stations for a more economic network design.



Fig. 2 Transmission of IP data over DVB-T

### 2.2 GPRS

GPRS (General Packet Radio Service) is the new standard for data transmission on the basis of existing GSM-networks [5]. The essential characteristic, which turns GPRS into a more advantageous hybrid system component than the classical circuit-switched GSM-data transmission is its packet orientation. It requires no time consuming connection establishment and thus enables the network to be operated more efficiently. This turns out to be especially suited for the described hybrid system services “E-Newspaper” and MP3-on-demand with their short and spontaneous interaction sessions. A transparent and user friendly billing, volume based or as a flat rate, can efficiently be integrated in the pricing of the service offers (e.g. flat rate for monthly subscription of the “E-Newspaper”).

From the technical point of view, the system architecture of GPRS allows to couple external IP-based networks, like the backbone network connecting GPRS and DVB-T (Fig. 3) directly over so-called GGSN (*Gateway GPRS Serving Node*) nodes.

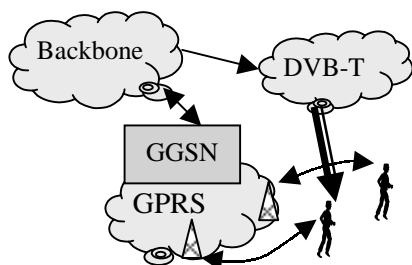

Fig. 3 GPRS and external IP-networks

### 3 Hybrid System

#### 3.1 General approach

One basis for the development of this backbone network is the ETSI standard of a GSM interaction channel for the DVB-system [6]. Another basis is the specification of a hybrid system with DAB (*Digital Audio Broadcasting*) and GSM by the European MEMO-project, finished in 1999 [1]. Succeeding projects that have started recently are MCP (*Multimedia Car Platform*) [11] and DRIVE (*Dynamic Radio for IP-Services in Vehicular Environments*) [13], which both develop a more extensive architecture combining different kinds of broadcast networks, like DAB and DVB-T, with different cellular networks in order to provide mobile multimedia services adaptively in a heterogeneous wireless network environment. As no further results of these projects exist so far, these projects could not provide input to our research at this moment but they will surely influence our considerations in the future.

#### 3.2 ETSI reference model

In its DVB-standard for GSM-interaction ETSI specifies a general platform for the realization of a DVB-GSM-hybrid system for interactive services (Fig. 4).

#### 3.3 MEMO reference model

MEMO (*Multimedia Environment for Mobiles*), a project within the European ACTS (*Advanced Communications Technology and Services*) program, provided a complete system specification for a DAB-GSM system in 1999, available in the internet [1]. Fig. 5 shows the function blocks of the MEMO model in small, dark printed blocks, which are described in more detail in the following section.

#### 3.4 Hybrid System based on MEMO

As shown in Fig. 5, the (bright printed) function units of the ETSI model perfectly map onto the MEMO blocks. Since the two models are compatible and the MEMO model is much more detailed, the hybrid system structure of this work is developed on the basis of MEMO. In this work we describe the adaptations necessary when passing from DAB/GSM (MEMO) to our proposed DVB-T/GPRS system.

In our hybrid system model we distinguish between two service classes: Interactive Broadcast Services (IBS) and Personal Services (PS). The data flow is illustrated in Fig. 5 with bright arrows for IBS and for PS with black arrows.

In IBS, data is transmitted in broadcast mode over DVB-T to all users. Each user can establish an individual, bi-directional interaction session (point-to-point) over GPRS, which is not coupled with the DVB-T downlink on the transport layer. Coupling is only done on the application layer, e.g. for updating content of the E-Newspaper by a discussion board contribution.

In Personal Service systems, also the data which is

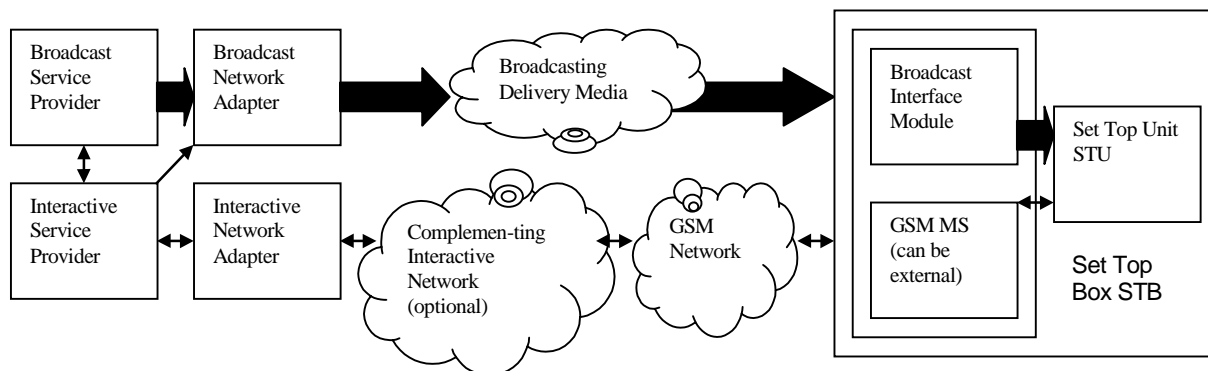
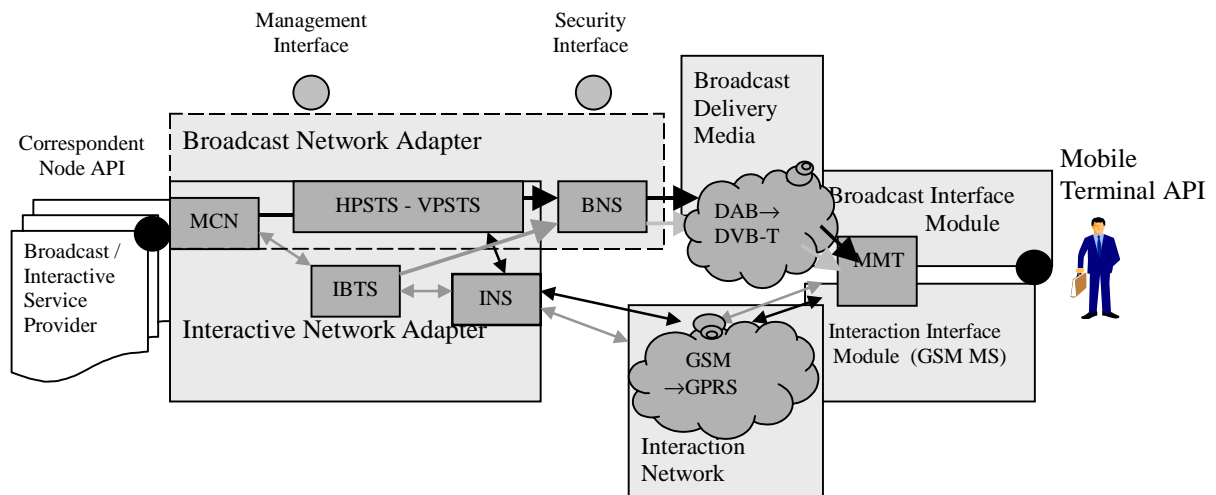

Fig. 4 ETSI- hybrid system model [6]



**Fig. 5** Hybrid system model by ETSI and MEMO

transmitted on the DVB-T downlink, is addressed individually on the IP level and is thus transmitted in a point-to-point mode. The bandwidth of the broadcast data pipe supplying one area is consequently shared among all active users. GPRS is coupled on TCP/IP layers as a return channel, but could additionally also provide an independent interaction channel, like in IBS (for example: in classic web surfing, requests and acknowledgements would use GPRS from the user to the network, the data transfer to the user could use DVB-T or also GPRS).

## 4 System Features and Protocols

The function blocks that form the hybrid system backbone, shown in Fig. 5, are in detail:

### **MCN** – *MEMO Correspondent Node*

Physical terminal that serves as a platform for the offered services, for example an ordinary internet host (PS service) or server of a service provider (IBS service).

### **HPSTS** – *Home Personal Service Transport Server*

### **VPSTS** – *Visited Personal Service Transport Server*

Perform the transport-, routing- and addressing functions, necessary for PS.

### **IBTS** – *Interactive Broadcast Transport Server*

Performs the corresponding functions for IBS services.

### **INS** – *Interactive Network Server*

Access server between VPSTS / IBTS and the GPRS-network.

### **BNS** – *Broadcast Network Server*

Receives data from the IBTS / VPSTS and prepares it for the transmission over DVB-T.

### **MMT** – *Mobile Multimedia Terminal*

Physical unit in the end user terminal, which contains the DVB-T receiver and the GPRS-transceiver.

Because of the different characteristics concerning the way of transferring data in the IBS- and PS- classes, two different system and protocol structures have been specified on the basis of MEMO, as we will show in the following sections.

### 4.1 Hybrid System for Interactive Broadcast Services (IBS)

In this section, we refer only to the protocols for IBS data transport in the backbone network and to the wireless interface. Our concept is based on the MEMO specification for IBS services [1], which also deals with other aspects like the way of transferring the broadcast data objects and the routing between the servers, which is out of the scope of this paper.

Fig. 6 shows on the left side the protocols of the DVB-T downlink and on the right side the protocols of the GPRS interaction channel. The necessary adaptations we have made because of the exchange of DAB/GSM with DVB-T/GPRS are marked by dark printed blocks and arrows. In case of the downlink, the lower DAB-layers have to be replaced with the transmission modes of DVB-T. The corresponding substitute on layer two is the MPEG2-transport stream and above the MPE-method for encapsulating IP datagrams (compare Section 2.1). As DVB-T does not specify a protocol on the transport layer like the MOT (*Multimedia Object Transfer*) in DAB, connectionless UDP or a solution called TCP-Tunnelling [7] has to be used. The protocol BNSP (Broadcast Network Submission Protocol) was specially developed by MEMO to enable the exchange of control information between the servers and can also be used for DVB-T with only minor adaptations.

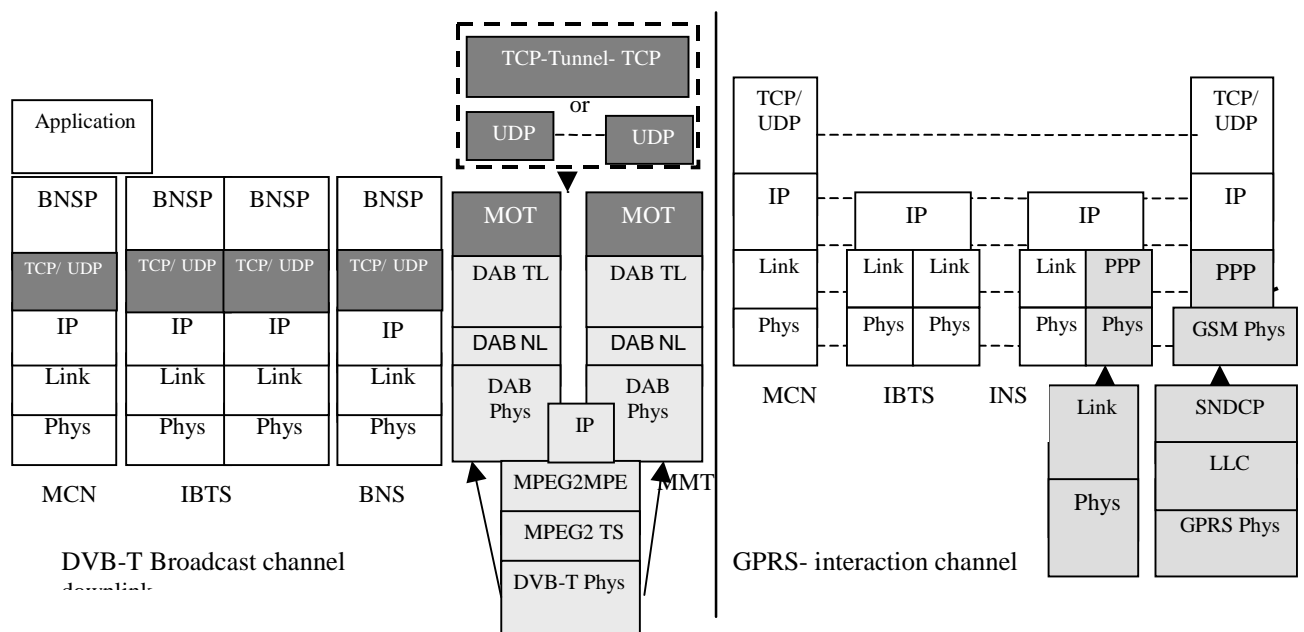

Fig. 6 Transport protocols for IBS services

In the interaction channel, the lower layers consist of the GPRS radio transmission modes and other protocols of GPRS, like SNDCP (*Sub Network Dependent Convergence Protocol*) and LLC (*Link Layer Control*) [5]. The PPP (*Point-to-Point Protocol*), that is used in MEMO for encapsulating data into the circuit switched GSM links, is therefore no longer needed, as GPRS is packet switching and makes it possible to transport IP data transparently above the underlying transmission modes, like for example ATM or frame relay in the backbone networks.

#### 4.2 Hybrid System for Personal Services (PS)

For Personal Services (PS) we need a round-trip connection over DVB-T and the GPRS return channel. The combined protocol structures are shown in Fig. 7. Basis is again the corresponding MEMO specification, for PS transport [1]. At the wireless interface, the same adaptations concerning the lower DAB/DVB-T and GSM/GPRS-layers like in IBS are necessary. On higher protocol layers, TCP can be used directly in a slightly modified version (TCP\*) for broadband wireless transmission systems. Details concerning these modifications in increased window-size and suppressed congestion control concerning the different characteristics of wireless transmission compared to fixed networks, can be found in [1]. The FEC-layer (Forward error correction) additionally

inserted by MEMO can be dropped as DVB-T has already a comparable error correction based on Reed-Solomon-Codes. As the PPP protocol in the GPRS channel is no longer necessary (compare Section 4.1), also the L2TP- protocol (*Layer 2 Tunneling Protocol*) used for PPP- transport between VPSTS and INS, is no longer needed. Besides these data transport functions, routing/addressing and mobility management is specified in the MEMO-PS specification [1]. Analogous adaptations have to be done for DVB-T/GPRS.

#### 4.3 Prototype Implementation

To demonstrate our solution we have built a prototype implementation based on a DVB-T - IP platform, which has been developed at the TUM in cooperation with the company Rohde & Schwarz, Munich [2, 8]. For the implementation we have selected the Interactive Broadcast Service “my-MP3”, which allows the mobile user to select multiple MP3 files from a distant server via a narrowband cellular channel and to receive the files via DVB broadcast. The service control on the server side is realized by servlets in a common web server.

Since a GPRS testbed has not been available yet, we relied on the GSM data channel for the emulation of the narrowband cellular return channel. As the results of our demo application were very promising, a field test using a real GPRS infrastructure is planned as future step.

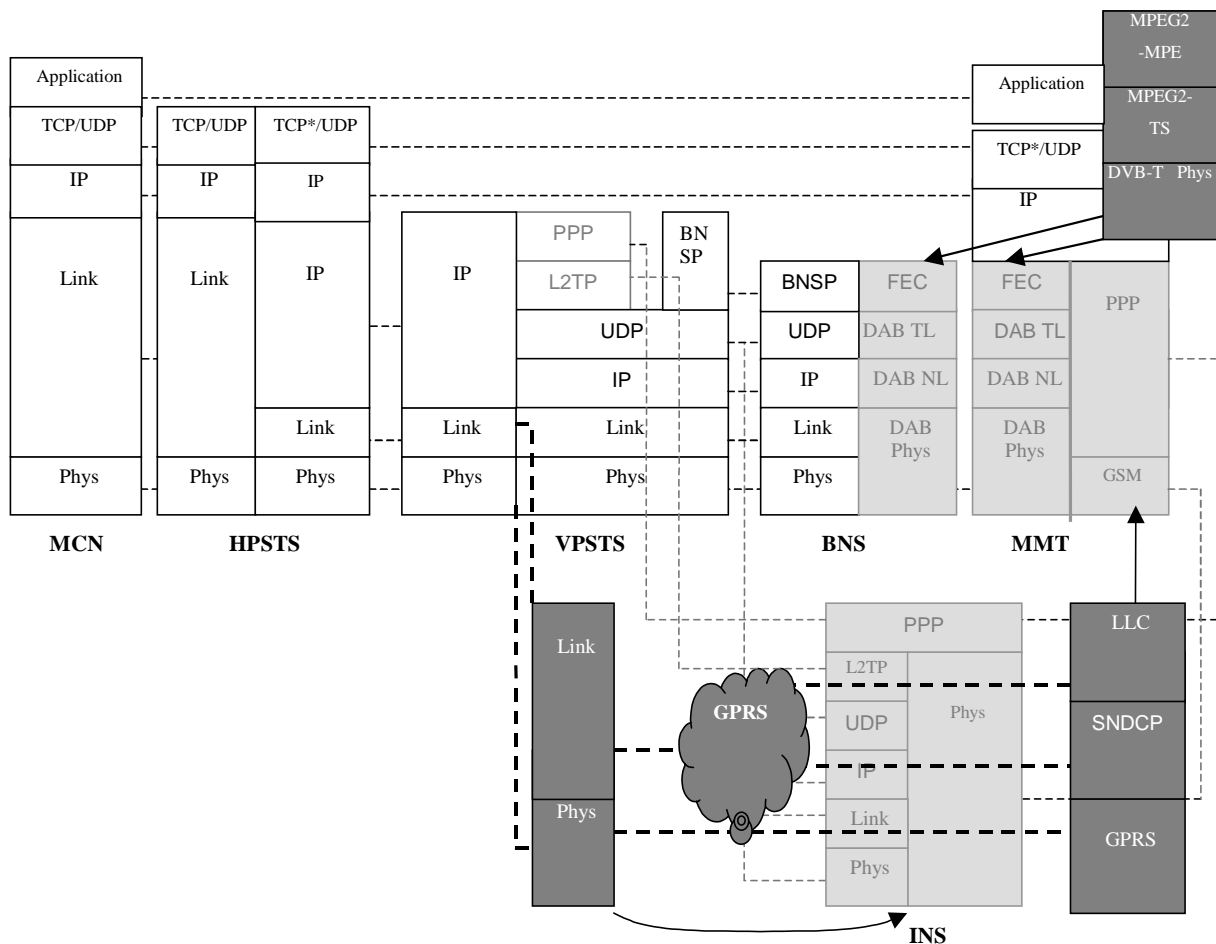

Fig. 7 Transport protocols for personal services

## 5 Realization Scenarios

### 5.1 Network Aspects

In this section we briefly examine how the previously developed hybrid system could be operationally realised in Germany according to the network design of DVB-T and GPRS. GPRS is considered as a fully operational network available everywhere. For DVB-T we suppose a transmission mode with 16 QAM-modulation and 2/3 error coding rate, providing a transmission rate of 13,3 Mbit/s. More than 45 frequency channels will be available for DVB-T in Germany in the VHF/UHF spectrum. On basis of these assumptions, the „Institut für Rundfunktechnik“, Munich, determined the availability of four countrywide supply channels and one regional supply level everywhere and of a sixth additional level in big cities, built up by single frequency networks in each city [9].

In this scenario, the “E-Newspaper” with its general news content could be broadcasted in one of the nationwide receivable channels, whereas the local

offers could be transmitted differently in the supply areas of the big cities.

In case of the MP3 service the regional supply levels with smaller transmission areas and consequently less users per area should be used. A central service control containing the functionality of MCN and IBTS would then receive the GPRS request for a music file together with the location information of the requesting user(s). With this, the chosen file can be transported over an IP backbone to the corresponding DVB-T transmission area, where it is encapsulated by a BNS server into the MPEG stream that is broadcasted there.

### 5.2 Terminal Aspects

There are several critical factors to enable future mobile terminals to offer hybrid system services. First of all a quite large DVB-T receiver would have to be integrated in addition to a GPRS transceiver. Furthermore an effective software and programming interface is needed, especially for the navigation between the partly interactive, digital TV programs and the supplementary services, described here. An useful solution should be based on the new, commonly

accepted standard for DVB set top boxes, called MHP (Multimedia Home Platform) [10]. The MCP project (see Section 3.1) is actually working on a MHP based terminal architecture, optimized for mobile, especially car based services. The first prototype is expected on the IFA 2001. First devices could be available in 2002 [11]. Also, the terminal would have to contain a sufficiently big color display. Consequently, there are high requirements concerning the power consumption to realize an acceptable usage time. According to statements from semiconductor companies and evaluations of the future technological development of these system components, these requirements could be met in the next years.

Notebooks turn out to be principally suitable terminals, as they offer full portable computer performance concerning memory, speed and multimedia functions. On the other side, they are not efficient for private customers because of their comparatively high complexity and price. In this case, an integrated terminal would be the better solution. An example is the Nokia Mediascreen, a prototype for mobile DVB-T and GSM services and television, having approximately the size of a book [12]. Such integrated terminals could later also be reduced to the size of the planned UMTS smartphones, as a „all-in-one“ mobile multimedia terminal.

### 5.3 Aspects of Regulation and Commercialization

The provision of new mobile services as described in this paper will depend on the co-operation of several different stakeholders. One major open question regarding for example Germany is the time and the way of the implementation of DVB-T.

The implementation of DVB-T concerns the network infrastructure necessary for mobile reception, the introduction strategy and the estimated revenue a service provider would have with DVB-T. Several different introduction strategies from a step by step evolution to an immediate change from analogue to digital transmission have been discussed between the involved stakeholders. At present, an insular implementation within city areas is planned for this year in Germany. Other European countries like UK already have deployed DVB-T infrastructure.

The success of DVB-T will not only depend on the benefits of the digital transmission for TV programs. Regarding the immense infrastructure costs, additional benefits for the users are necessary to facilitate new revenue possibilities. So, supplementary services, as described in this paper, will play an important role regarding the introduction of DVB-T.

As DVB-T is originally a broadcast medium, also different regulatory aspects have to be considered. Depending on the content of a broadcast program,

different rules have to be fulfilled to guarantee a primary supply for a broad majority of the population. It is yet not clear, how the described supplementary multimedia services have to be classified regarding regulatory rules.

For the commercial success of such services, the roles of the different parties involved have to be regarded. The provider of the described services could either be a network operator (GPRS or DVB-T) itself or an independent service operator. The latter could purchase capacity from network operators to supply his service or he could sell his service to network operators. Based on that, different business plans can be developed considering costs and potential sales depending on pricing strategies and estimated numbers of users.

In our opinion the introduction of DVB-T and the attractiveness for business is strongly correlated with new multimedia information and communication services that could be provided in addition to the TV program, either independently or/and integrated as a "mobile multimedia package".

## 6 Conclusions

We have shown that wireless broadcast networks are an important system component of the future wireless infrastructure towards *Mobile Internet*. In particular, the combination of DVB-T and GPRS has been investigated and a solution for a hybrid system model based on the results of the ACTS MEMO project has been shown. In respect with the level of interoperability versa broadcasting two general system versions have been described. Electronic-newspaper and MP3-music-delivery have been taken as service examples to illustrate typical business applications of our solution. In fact, new Internet based information services like those presented are considered to be a driving force for the rollout of DVB-T in Europe, even in countries where regulatory aspects are not clear yet and where the domination of satellite and cable TV slows down terrestrial TV digitalization e. g. in Germany. The authors consider DVB-T as an essential component of the wireless infrastructure to deliver broadband broadcast like data services.

## 7 Acknowledgements

This work has been done in a joint project between the Institute of Communication Networks at the Munich University of Technology and the Vodafone Pilotentwicklung GmbH, Munich. We like to thank Jochen Hertle, head of telecommunications at Vodafone Pilotentwicklung for many insightful discussions and his support of our work. We also like to thank Rohde & Schwarz, Munich, for the support with the prototype realization.

## 8 References

- [1] Project MEMO “ Multimedia Environment for Mobiles”; <http://MEMO.lboro.ac.uk/>; 1999.
- [2] W. Kellerer, P. Sties, J. Eberspächer. IP based Enhanced Data Casting Services over Radio Broadcast Networks. In Proceedings of IEEE ECUMN 2000 Conference, Colmar, October 2000.
- [3] ETSI- TR 101 190: Digital Video Broadcasting (DVB); Implementation guidelines for DVB terrestrial services; Transmission aspects; V1.1.1 (1997-12)
- [4] ETSI EN 301 192 European Standard: Digital Video Broadcasting (DVB); DVB specification for data broadcasting V1.2.1 (1999-06)
- [5] C. Bettsteter, H.-J. Vögel, J. Eberspächer. GSM Phase 2+ General Packet Radio Service GPRS: Architecture, Protocols, and Air Interface. IEEE Communication Surveys, 3rd quarter 1999.
- [6] ETSI EN 301 195 European Standard: Digital Video Broadcasting (DVB); Interaction channel through the Global System for Mobile communication (GSM); V1.1.1 (1999-02).
- [7] P. Sties, W. Kellerer. Radio Broadcast networks Enable Broadband Internet Access for Mobile Users. In Proceedings of EUNICE’99, Barcelona, Spain, September 1999.
- [8] P. Sties, J. Eberspächer, W. Kellerer, B. Kreutzer, H. Reichel, G. Zurek-Terhardt: Broadband Internet Access Over Digital Video Broadcast (DVB). In proceedings of NOC’99, Delft, June 1999.
- [9] G. Petke, R. Brugger,: Frequenzbedarf für den digitalen terrestrischen Rundfunk; Studie des Instituts für Rundfunktechnik (IRT) für die Direktorenkonferenz der Landesmedienanstalten DLM; Juli 1999.
- [10] ETSI TS 101 812 Technical Specification: Digital Video Broadcasting (DVB); Multimedia Home Platform (MHP) Specification 1.0 (2000-07).
- [11] MCP (Multimedia Car Platform) project; Homepage: <http://mcp.fantastic.ch>;
- [12] DVB-Newsletter: The brave new world of DVB-T; [http://www.dvb.org/dvb\\_news/dvb\\_new\\_sletter.htm](http://www.dvb.org/dvb_news/dvb_new_sletter.htm); März 2000.
- [13] DriVE (Dynamic Radio for IP Services in Vehicular Environments); Homepage: <http://www.comnets.rwth-aachen.de/~drive/>;